

Clarke®

LANDSCAPER



SELF PROPELLED LAWNMOWER
MODEL NO: CSP56LM

PART NO: 2345686

ASSEMBLY & USER INSTRUCTIONS

UK
CA | CE



ORIGINAL INSTRUCTIONS

GC11/25

INTRODUCTION

Thank you for purchasing this CLARKE Lawnmower.

Before attempting to use this product it is essential that you read this manual thoroughly and carefully follow all instructions given. In doing so you will ensure the safety of yourself and that of others around you, and you can also look forward to the product giving you long and satisfactory service.

If however, having followed the instructions in this booklet carefully, you encounter problems, take the unit to your local CLARKE dealer.

Ensure that all components are present. Should any loss or damage be apparent, please contact your CLARKE dealer immediately.

Please keep these instructions in a safe place for future reference.

GUARANTEE

This CLARKE product is guaranteed against faulty manufacture for a period of 12 months from the date of purchase. Please keep your receipt as proof of purchase.

This guarantee is invalid if the product is found to have been abused or tampered with in any way, or not used for the purpose for which it was intended.

Faulty goods should be returned to their place of purchase, no product can be returned to us without prior permission.

This guarantee does not effect your statutory rights.

ENVIRONMENTAL PROTECTION

DO NOT dispose of this product or associated components with general household waste. All tools, accessories and packaging should be sorted, taken to a recycling centre and disposed of according to the laws governing Waste Electrical and Electronic Equipment.

Always dispose of oil and petrol in an manner which is compatible with the environment. Never pour oil or petrol into drains. Contact your local recycling centre for advice on the disposal of oil and petrol.

SPECIFICATION

Model	CSP56LM
Part number	2345686
Dimensions L x W x D	1520 x 550 x 1050 mm
Weight (empty)	35 kg
Engine	SRV225 (Euro V)
Engine capacity	224 cc
Power	4.4 kW
Speed of rotation	3600 rpm
Fuel type	Petrol
Oil capacity & type	0.45L (SAE 10W/30)
Fuel tank capacity	1.2 L
Fuel consumption (max rpm)	1.4 L/hr
Running time @75% load	1 hr 8 min (calculated)
Spark plug type	F7RTC
Width of cut	56cm
Cutting height range	25-75mm (7 adjustments)
Collection capacity	65L
Drive speed	1m/s
Rounded sound power level	98 dB

GENERAL SAFETY PRECAUTIONS

WARNING: AS WITH ALL MACHINERY, THERE ARE CERTAIN HAZARDS INVOLVED WITH ITS OPERATION AND USE. EXERCISING CAUTION WILL REDUCE THE RISK OF PERSONAL INJURY.

WARNING: CERTAIN INTERNAL COMPONENTS OF THIS MACHINE CONTAIN LEAD IN SMALL QUANTITIES.

GENERAL SAFETY POINTS

1. If not used properly, this lawnmower can be dangerous and can cause serious injury to the operator or others. The operator is responsible for following the warnings and safety instructions in this manual and displayed on the lawnmower. The warnings and safety instructions **MUST** be followed to ensure reasonable safety and efficiency when in use.
2. **NEVER** allow children or people unfamiliar with these instructions to use the lawnmower. Local regulations may restrict the age of the operator.
3. **NEVER** operate the lawnmower when you are tired, ill or under the influence of alcohol, drugs or medication.
4. **ALWAYS** wear suitable clothing and footwear.
5. Only use the lawnmower in the manner and for the functions described in these instructions.
6. The operator or user is responsible for accidents or hazards occurring to other people or their property.

SAFETY IN USE

1. **NEVER** operate the lawnmower in a confined space where exhaust fumes (carbon monoxide) can collect.
2. **NEVER** attempt any maintenance on your lawnmower while the engine is hot.
3. **NEVER** put hands near the grass discharge chute whilst engine is running.
4. **NEVER** use the mower unless the grass box is in position or the guard flap is closed.
5. **NEVER** pick up or carry the lawnmower while the engine is running.
6. **NEVER** walk backwards when mowing in case of tripping.
7. **NEVER** cut grass by pulling the mower towards you.
8. **NEVER** tamper with the engine settings which are pre-determined by the manufacturer.

9. **ALWAYS** stop the engine before pushing the mower across surfaces other than grass and when transporting the lawnmower to and from the area to be mowed.
10. **ALWAYS** reduce the throttle setting during engine shut down and turn off the fuel valve at the conclusion of mowing.
11. **ALWAYS** start the mower carefully with your feet well away from the blades, ensuring that the mower is level.
12. **ALWAYS** keep the lawnmower on the ground when mowing. Tilting or lifting the lawnmower may cause stones to be thrown out.
13. **ALWAYS** avoid using your lawnmower on wet grass wherever possible.
14. **ALWAYS** use the lawnmower in daylight or good artificial light.
15. **ALWAYS** stop the engine and wait until the blade has stopped, before leaving the mower unattended for any period or when re-fuelling.
16. **ALWAYS** stop the engine and wait until the blade has stopped:
 - before clearing a blockage.
 - before checking, cleaning or working on the mower.
 - if you hit an object. (**DO NOT** use your lawnmower until you are sure that the entire lawnmower is in a safe operating condition).
 - if the lawnmower starts to vibrate abnormally check it immediately.
17. Mowing on banks and slopes can be dangerous. **DO NOT** mow on banks or steep slopes of more than 15 degrees. Mow across the face of slopes, rather than up and down.
18. Beware of injuring toes or hands. **DO NOT** put hands or feet near a rotating blade.





FUEL SAFETY

WARNING: PETROL IS HIGHLY FLAMMABLE

1. Store fuel in a cool place in a container specifically designed for the purpose. In general, plastic containers are unsuitable.
2. Refuel outdoors only and **DO NOT** smoke while re-fuelling.
3. Add fuel **BEFORE** starting the engine. **NEVER** remove the cap of the fuel tank or add fuel while the engine is running or when the engine is hot.
4. If petrol is spilled, **DO NOT** attempt to start the engine but move the machine away from the area of spillage and avoid creating any source of ignition until petrol vapours have dissipated.
5. Replace all fuel tank and container caps securely.
6. Move the lawnmower away from the fueling area before starting.

SAFETY SYMBOLS

The full technical specification of the lawnmower is printed on a label on the machine. The meanings of the markings and symbols are shown below

	Read instruction manual before use		Wear ear protection when using this product
	Wear eye protection when using this product.		Wear protective footwear

LIST OF ITEMS SUPPLIED

The machine is delivered with the following components:

- Upper handlebar with fixings (connected by cables)
- Lower handlebar
- Tool kit containing spark plug spanner/tommy bar and open spanner
- Grass Collection Box/bag assembly
- Grass discharge chute (fitted)
- Blanking plate
- Side discharge duct
- Fixings pack (bolts/washer/nuts)

OVERVIEW

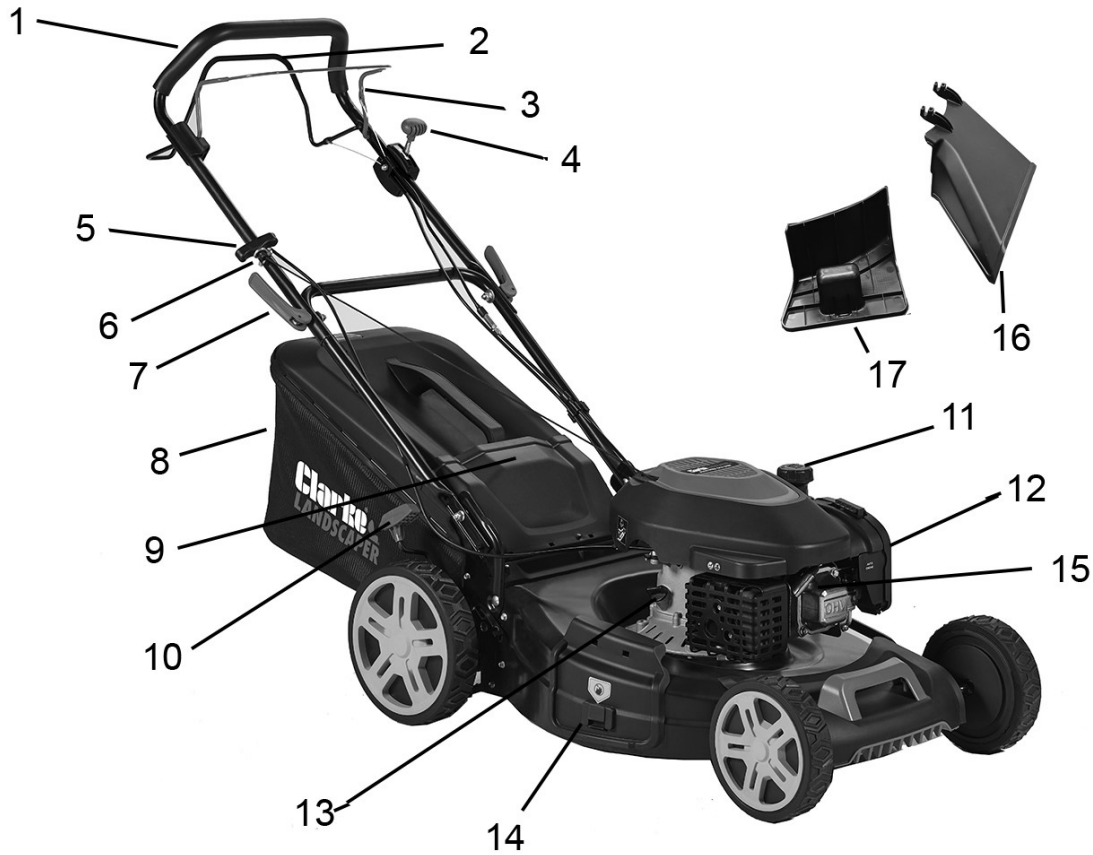

1	Upper handlebar
2	Driving lever
3	Engine brake lever
4	Engine speed control lever
5	Starter pull-cord handle
6	Cord retaining loop
7	Quick release handle
8	Grass collection box/bag
9	Guard flap

10	Height adjustment lever
11	Fuel filler cap
12	Inlet air filter housing
13	Oil filler and dipstick
14	Side discharge outlet flap
15	Spark plug
16	Blanking plug
17	Side discharge duct

ASSEMBLY

UPPER & LOWER HANDLEBARS

1. Attach the lower handlebars to the frame brackets with the bolts, washers & nuts provided. Note that the handlebars can be set at one of two angles by selecting either hole for the bolts.
2. Connect the upper handlebars to the lower handlebars using the bolts and plastic locking handles. Lock in the operating position.
3. If wished, pull the starter 'Pull Cord', until you can locate it in the pull cord attachment ring on the handlebar where it is ready to use.

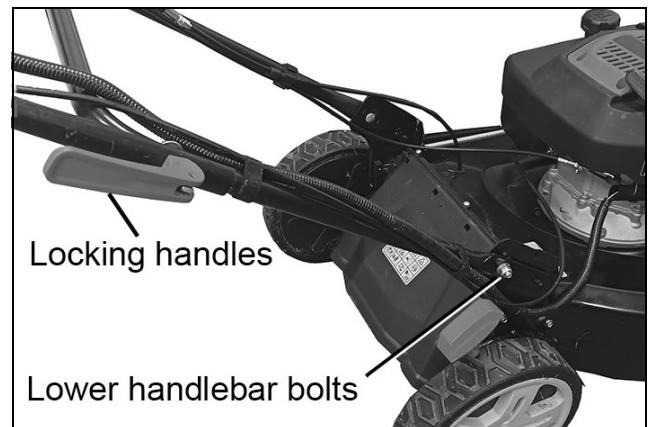

INSTALLING THE GRASS COLLECTION BOX

1. To attach the grass collection box, lift the guard flap and hook the grass bag frame onto the cutter housing. Release the guard flap to secure the grass box in place.
2. Ensure the grass collection box is securely located.
3. To remove, raise the flap, grasp the grass bag handle and lift away.



NOTE: Where grass collection is not required you can use the mower without the grass box but **MUST ENSURE THE GUARD FLAP IS FULLY CLOSED.**

BLANKING PLATE INSTALLATION - (FOR SIDE DISCHARGE)

1. Lift the rear cover and fit the Blanking Plate onto rear discharge outlet and hook into place.
2. Lower the rear discharge cover.

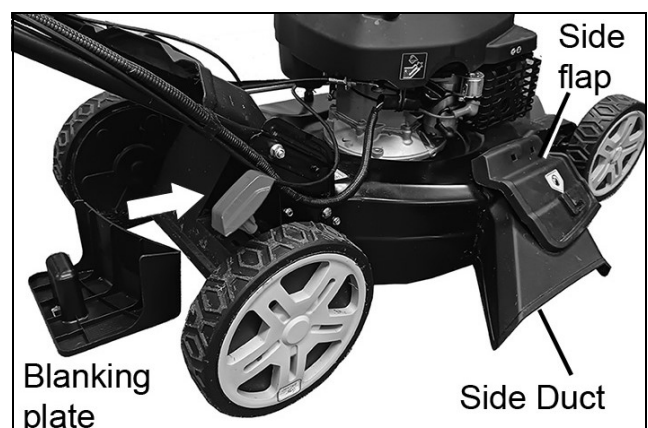

SIDE DUCT INSTALLATION

1. Lift the side flap against the resistance of the spring until high enough to introduce the side duct. Clip this into place underneath the side flap to achieve side discharge of the grass cuttings from the machine.

Assembly is now complete, but before using the lawnmower, certain important checks **MUST** be made which are described in the following pages.

ENGINE OIL

IMPORTANT: THE ENGINE FITTED TO THIS LAWNMOWER IS SUPPLIED WITHOUT OIL DURING SHIPMENT. ENSURE THE ENGINE IS FILLED WITH THE CORRECT AMOUNT OF A SUITABLE OIL BEFORE STARTING THE ENGINE.

Serious damage may result if the engine is run without oil.

1. To fill with oil, remove the oil filler cap and fill to the MAX mark on the dipstick, using a good quality SAE10W/30 4-stroke oil (part no; 3050845 - not supplied).
2. Change the oil after the first five hours operation of a new mower (see Maintenance), and thereafter every 25 working hours.
3. **ALWAYS** change the oil while the engine is warm - but not hot. **NEVER** attempt any maintenance on a hot engine.
4. When checking the oil level, always clean around the dipstick before unscrewing it. Once removed, wipe it with a clean cloth then replace, screwing down fully. Remove once more and check the level.
5. Get into the habit of checking the oil level before each use.

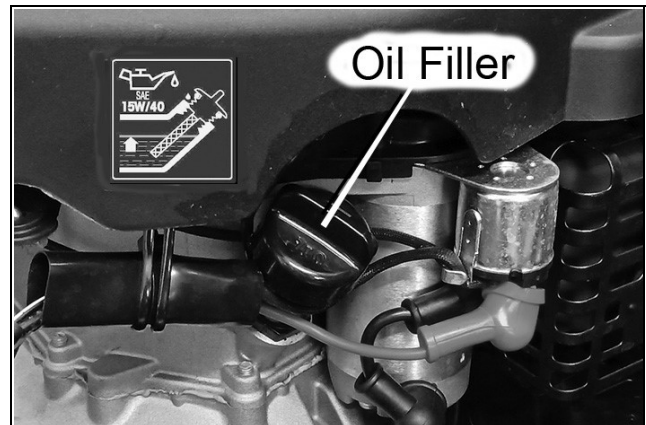

FUEL (PETROL)

WARNING: PETROL IS HIGHLY FLAMMABLE

1. Fill the fuel tank with regular grade unleaded petrol.
2. **DO NOT** fill or refuel when the engine is hot.
3. **DO NOT** fill the fuel tank whilst smoking or near naked flame.

4. **DO NOT** remove the fuel filler cap whilst the engine is hot or running. **ALWAYS** allow the engine to cool for at least 2 minutes before re-fuelling.
5. To avoid introducing dirt into the fuel system, wipe all grass and dirt from the petrol filler cap before unscrewing it.
6. It is recommended that you fill the tank through a funnel with a filter.
7. Wipe away any spillages before starting.
8. Use fresh petrol. Stale fuel can cause the carburettor to clog up.
9. **DO NOT** refuel indoors or in an unventilated area.
10. **DO NOT** operate engine if petrol has been spilled. Move lawn mower well away from the scene before starting.



STARTING & OPERATING

USING THE CONTROLS

ENGINE BRAKE LEVER

Pull back the red engine brake lever before starting the engine. Release the engine brake lever to stop the engine.

- If keeping the red engine brake lever released, the starter rope will not pull out due to the flywheel brake.

Holding the engine brake lever and handlebar continuously will keep the engine and blade rotating. When releasing the engine brake lever, the engine will stop running and the blade will stop rotating.

- When you need to stop work, release the engine brake lever to stop the engine.

DRIVING LEVER

The driving lever controls the transmission via cables to disengage and engage in order to drive /stop the rear wheels.

Hold the black driving lever and the lawnmower will move forward. Release the driving lever and the lawnmower will stop.

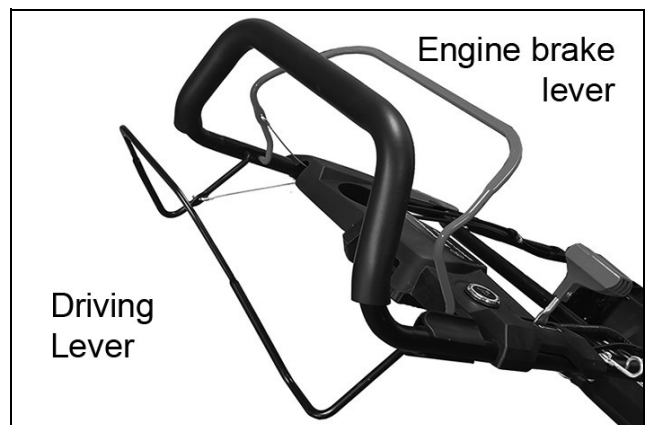

CAUTION

- Release the driving lever before starting the engine. If holding the driving lever, the mower will move forward when you pull the starter handle.
- When operating the driving lever, keep it either fully released or fully held. Action should be prompt and continuous.
- When you choose to operate the lawn mower in self-propelled mode, just hold the driving lever continuously. It can give longer life to the clutch.

STARTING THE ENGINE

1. Release the driving lever. If the driving lever is held during starting the mower will move forward.
2. Stand at the operating position behind the lawnmower and hold the brake lever against the handlebar.
3. Allow the cord to recoil slowly, then pull the handle firmly towards you to its full extent to start the engine. You may need to do this more than once. Pull the starting rope slightly until you feel the resistance of the engine and pull the rope smartly. The engine should start.

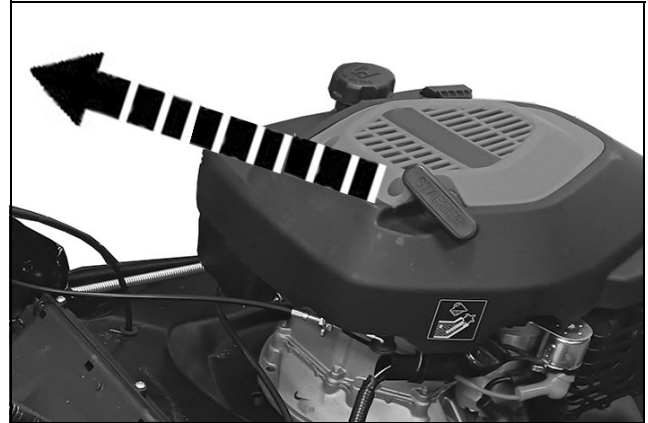

- The blade will rotate as soon as the engine is running.

It is easier to start the engine on clean or cut lawn because the blade can rotate freely.

ENGINE RUNNING

1. Move the control lever to the "Fast" position to increase the engine speed and the "Slow" position to slow down.
2. Once started, gently pull the self-propelled drive lever towards the handle, thereby engaging the drive. **ALWAYS** start the engine with the drive disengaged.
3. Releasing the power-drive control lever stops the drive to the rear wheels. To stop the mower, - release the power-drive control lever, then adjust the throttle lever.

CUTTING HEIGHT ADJUSTMENT

By moving the adjustment lever, the chassis height of the lawn mower can be adjusted to change the cutting height.

1. Move the adjustment lever rearward to raise the cutting height.
2. Move the adjustment lever forward to lower the cutting height.

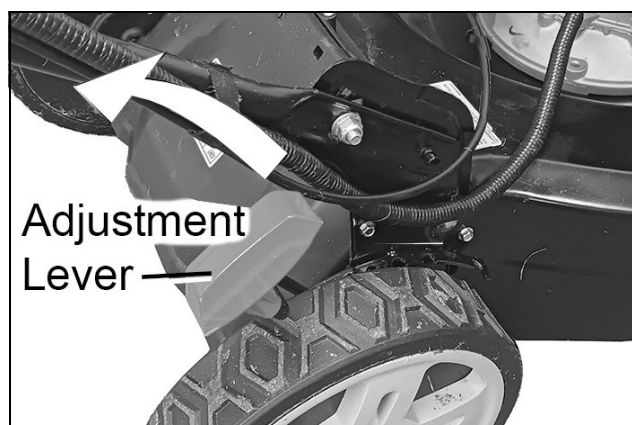

USING THE MOWER

DO NOT overload your lawnmower. Correct height adjustment, will help reduce engine overload and will help prevent damage to your lawnmower.

Starting the machine on clear, level ground will be easier because the blade can rotate freely.

Avoid steep slopes of more than 15 degrees, especially if the grass is damp as this could cause you to slip and loose control of the mower.

Set the height of cut by pulling the adjustment lever away from the location slots and moving to the selected position.

1. When mowing long thick grass, set the cutting height to its highest setting and lower with each successive cut.
2. Start mowing from the outside edge of the lawn, mowing in strips in alternate directions, overlapping slightly.
3. Mow twice a week in the growing season, your lawn will suffer if more than one third of its length is cut at one time and this may also result in poor grass collection.
4. **ALWAYS** make sure the lawn is clear of debris which could be thrown up by the blade.
5. Before use always visually inspect to see that blades are not worn or damaged. Replace worn or damaged blades before mowing.

SLOPES

Mow across slopes, not up and down. Avoid steep slopes (more than 15°), and be careful when changing direction. Mowing on a slope when the grass is damp or wet could cause you to slip, fall, and lose control of the mower.

CUTTING HEIGHT

1. Consult a local nursery or garden center for cutting height recommendations and advice about specific types of grasses and growing conditions in your area.
2. If you look closely, you'll see that most grass has stems and leaves. If you cut off the leaves, you'll scalp the lawn.
3. Let the grass recover between mowing. Your mower will work better and your lawn will look better.
4. If your grass gets too tall, cut it once at the highest cutting height setting, then mow again in 2 or 3 days. Don't take off more than one third of total grass height in any one mowing session or brown patches may develop.

CUTTING WIDTH

For an even lawn finish, overlap each mowing swath by approximate 5-10cm. If the grass is very tall or thick, use more overlap and a narrower mowing swath.

BLADE SPEED

The blade must spin very fast to cut properly. Always use the FAST throttle setting and keep the engine running at maximum rpm. If engine speed drops, it could mean the engine is being overloaded by the blade trying to cut too much grass. Mow a narrower swath, move the mower slower, or raise the cutting height.

BLADE SHARPNESS

A sharp blade cuts cleanly. A dull blade tears the grass, leaving shredded ends that turn brown. When your blade doesn't cut cleanly anymore, have it sharpened.

DRY GRASS

If the ground is too dry, mowing will stir up a lot of dust. Besides being unpleasant to work in, too much dust will clog the carburettor air filter. If dust is a problem, water your lawn the day before mowing. Mow when the grass is dry to your touch, but the soil is still moist.

WET GRASS

Wet grass is slippery and can make you lose your footing. Also, wet grass clippings will clog the cutter housing and collect in clumps on the lawn. Always wait for wet grass to dry before mowing.

FALLEN LEAVES

When equipped with the grass bag, your mower can be used to pick up fallen leaves for disposal. If using the mower to bag large amount of fallen leaves, and not for mowing, set the cutting height adjustment lever at highest setting.

If you want to mulch fallen leaves into your lawn, don't let the leaf cover get too deep before you begin. For best results, start mulching while grass still shows through the leaf cover. In places where fallen leaves completely cover the grass remove the leaves by raking, or install a grass bag, so your mower can pick them up for disposal.

CLOGGED CUTTER HOUSING

Before clearing a clogged cutter housing, stop the engine and tilt the mower so the carburettor side is up. Clear a clogged deck with a stick or blade.

AFTER USE AND STORAGE

Proper storage preparation is essential for keeping your mower trouble-free and looking good. The following steps will help to keep rust and corrosion from impairing your mower's function and appearance and will make the engine easier to start when you use the mower again.

1. **NEVER** store the lawnmower with fuel in the tank inside a building where fumes can reach an open flame or spark.
2. Allow the engine to cool before storing the mower in a small enclosure.
3. To reduce fire hazard, keep the engine assembly and fuel storage area free of grass, leaves.
4. If the fuel tank has to be drained, this should be done outdoors.
5. Be careful of the sharp cutting blade during maintenance work.

CLEANING

Wash the mower, including the underside of the cutter housing. Wash the engine by hand and be careful to prevent water from entering the air cleaner and/or muffler

CAUTION: USING A GARDEN HOSE OR PRESSURE WASHING EQUIPMENT CAN FORCE WATER INTO THE AIR CLEANER. WATER IN THE AIR CLEANER WILL SOAK THE FILTERS AND CAN ENTER THE CARBURETTOR OR ENGINE, CAUSING DAMAGE.

CAUTION: WATER ON A HOT ENGINE CAN CAUSE DAMAGE. IF THE ENGINE HAS BEEN RUNNING, ALLOW IT TO COOL FOR AT LEAST 30 MINUTES BEFORE WASHING.

If using a garden hose or pressure washing equipment to clean the cutter housing, be careful to avoid getting water into controls and cables, or anywhere near the engine air cleaner or muffler opening.

FLUSHING WITH HOSE THE CONNECTOR

1. Connect the hose onto the cleaning nozzle and turn on the water switch to wash the chassis.
2. Start the engine and let the blades run at normal working speed for a few minutes (wash it on the grass or other suitable place).
3. **DO NOT** allow water or washed debris to enter a clean water source.

MANUAL CLEANING

If there is still debris after washing, use a plastic brush or cloth to clean it.

AFTER CLEANING

1. After cleaning, remove the hose and dry the surface of the lawn mower.
2. Stand the mower horizontally outdoors and start the engine until it reaches normal working temperature to evaporate residual moisture.
3. Turn off the engine and allow it to cool down.
4. After cleaning the lawn mower, let it dry. If necessary, repair the paint surface and apply a thin layer of anti-rust oil to any parts that may rust.

FUEL

Petrol will oxidise and deteriorate in storage. Old petrol will cause hard starting and it leaves gum deposits that clog the fuel system. If the fuel in your mower deteriorates during storage, you may need to have the carburettor and other fuel system components serviced or replaced.

The length of time that fuel can be left in your fuel tank and carburettor without causing functional problems will vary with such factors as fuel blend, storage temperatures and whether the fuel tank is partially or completely filled. The air in a partially filled fuel tank promotes fuel deterioration. Very warm storage temperatures accelerate fuel deterioration. Fuel deterioration problems may occur within 30 days or even less if the fuel was not fresh when you filled the fuel tank.

The warranty does not cover fuel system damage or engine performance problems resulting from neglected storage preparation.

You can avoid fuel deterioration problems by draining the fuel tank and carburettor.

- Use fresh and clean fuel.
- To slow deterioration, keep fuel in a certified fuel container.
- If long term storage (<30 days) is foreseen, drain the fuel tank and carburettor.

DRAINING THE FUEL TANK AND CARBURETTOR

1. Drain the fuel in the fuel tank and carburettor into a suitable container after releasing the spring clips securing the fuel tube connecting the tank and the carburettor.
2. Reconnect the tube once drained.

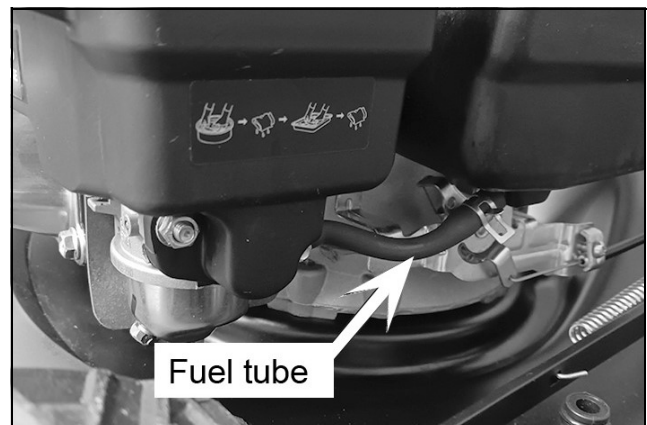

LONG TERM ENGINE CYLINDER PROTECTION

1. Remove the spark plug (See p18).
2. Pour a spoonfull of clean engine oil into the cylinder.

3. Pull the starter grip several times to distribute the oil in the cylinder. Reinstall the spark plug.
4. Pull the starter grip slowly until resistance is felt, then return the starter grip gently. This closes the valves so moisture cannot enter the engine.

MAINTENANCE

AFTER USE

To ensure the best performance from the lawnmower it should be kept clean. Always clean the lawnmower immediately after use so as not to allow grass cuttings and other debris to become dry and caked hard onto any of the internal surfaces. This will directly affect the cutting and grass collection performance.

Allow a period of time for the engine to cool before cleaning. Once the engine is cool, remove grass from under the machine with a brush. Make sure that the underside of the lawnmower deck is clean and clear of grass cuttings.

Ensure that the grass discharge chute and guard flap are clean and clear. The grass collection box must always be emptied after use and the interior cleaned and cleared of grass cuttings.

Make sure that the exterior of the engine is clear of all cuttings and dirt, especially around the silencer & air intake. Check the oil level.

Finally, wipe over the surface of your lawnmower with a dry cloth.

NEVER use solvents or chemical cleaners to clean your lawnmower.

Store your lawnmower in a cool, dry place where it will be protected from damage.

AT THE END OF THE MOWING SEASON

1. Remove and sharpen the cutting blade or replace the blade if found to have been damaged by debris /stones etc (for blade removal see overleaf).
2. Remove and clean the air filter.
3. Drain the petrol (see page 15).

MAINTENANCE SCHEDULE

Follow the hourly or calendar intervals, whichever occurs first. More frequent service is required when operating in adverse conditions.

AFTER FIRST 5 HOURS OF MACHINE USE

Change the engine oil (see page 18).

EVERY 25 HOURS OR EVERY SEASON

Change the oil and clean the air filter.

REPLACING THE DRIVE BELT

The self-propulsion system incorporates a drive belt which may after extensive use, require replacement.

1. Drain any remaining petrol from the lawnmower as described **on page 18**.
 2. Turn the machine over and remove the cutting blade.
 3. Remove the three screws holding the drive cover, and from above, pinch the retaining clip holding the cover to the machine body. Lift off the cover complete with the blade holder, sliding it off the drive shaft. The drive belt will now come away with the blade holder/driven pulley.
- The illustration shows the belt installed on the pulleys, complete with blade holder. The cover is absent to illustrate this.

Replace the defective drive belt and re-fit the blade holder and cover together, noting that a key (spline) engages the blade holder with the drive shaft. Press-fit the cover clip to the machine body and refit the three retaining screws

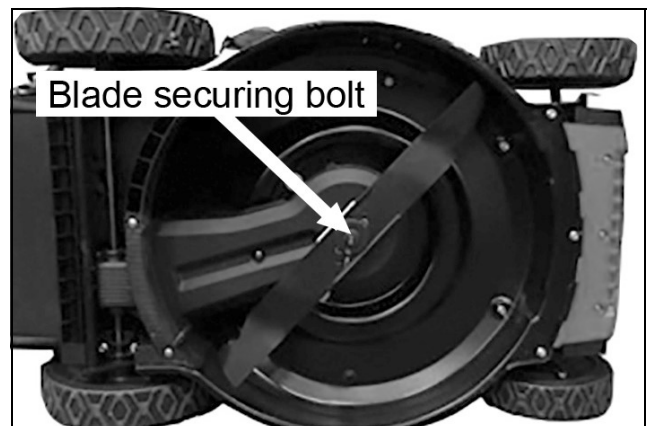
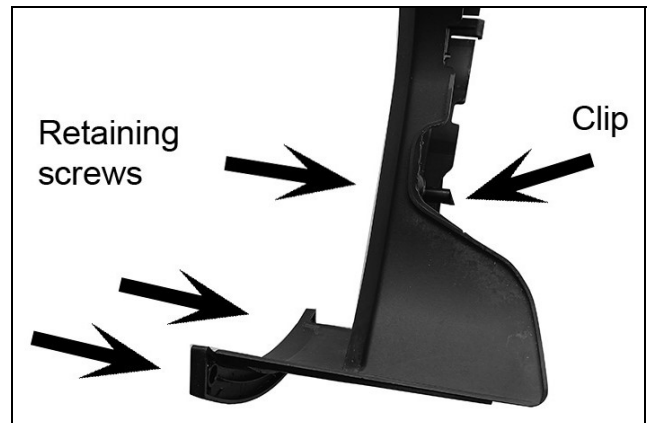

CLEANING THE AIR FILTER

Dirty air cleaner will restrict air flow to the carburettor, reducing engine performance. If you operate the mower in very dusty areas, clean the air cleaner more often than specified in the MAINTENANCE SCHEDULE.

1. Release the clip at the top to remove the air cleaner cover.
2. Remove the sponge filter elements from the air cleaner housing and replace them if damaged.

NOTE: If the engine is running without an air filter element or the filter element is damaged, dust will enter the engine, thereby accelerating wear. Such damage is not covered under warranty.

3. Wash with soap and warm water, rinse and dry or wash with a non-flammable solvent and let it dry.
4. Wipe off the dirt in the air cleaner housing and cover with a damp cloth. Be careful not to let dirt pas beyond the housing.
5. Refit the sponge air filter parts and clip the cover back into place.

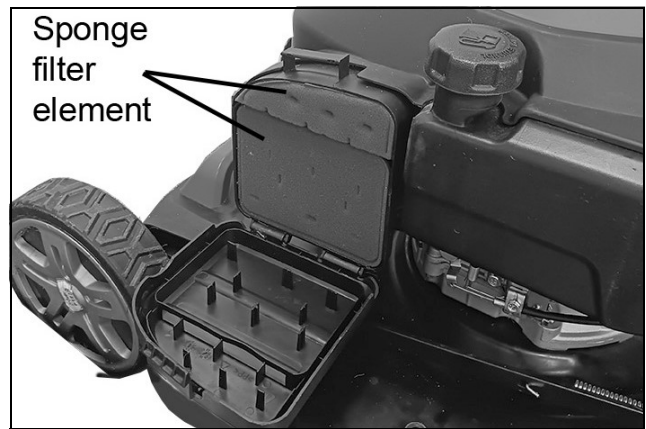

SPARK PLUG SERVICE

- Recommended spark plug: F7RTC
1. Disconnect the spark plug cap and remove dirt from the area.
 2. Use the spark plug wrench supplied to remove the spark plug.
 3. Inspect the plug and replace if the electrode is worn, pitted, or if the insulator is cracked or chipped. Clean the plug completely if you are going to reuse it.
 4. Measure the spark plug gap with a suitable gauge. The gap should be 0.7 - 0.8 mm. Correct the gap, if necessary by bending the side electrode.
 5. Refit the spark plug carefully by hand, to avoid cross-threading. Tighten with the spark plug wrench to compress the washer.
 6. Refit the spark plug cap/lead to the spark plug.

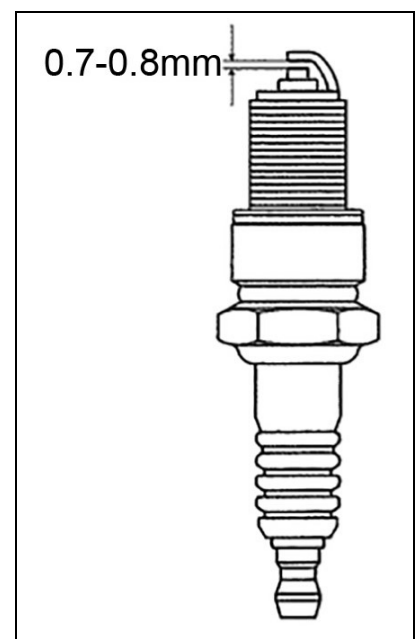

CHANGING THE OIL

1. Turn the mower on its side and pour the oil into a suitable container. Warm oil will drain faster than when cold.
2. When completely drained, set the machine upright and replace the oil filler/dipstick. Refill with CLARK SAE10W/30 (part no; 3050845) oil to the 'MAX' level on the dipstick.
3. **DO NOT** overfill. If overfilled, any excess oil can get transferred to the air cleaner housing and air cleaner. Screw in the oil filler cap/dipstick securely.
4. Dispose of old/spilled oil appropriately and wipe up any spillage.

ENVIRONMENTAL PROTECTION

One of the most damaging sources of environmental pollution is oil products. **NEVER** throw away used engine oil with domestic refuse or flush it down a sink or drain. Collect any oil in a leak proof container and take it to your local waste disposal site.

REPLACING THE DRIVE BELT

The self-propulsion system incorporates a drive belt which may after extensive use, require replacement.

1. Drain any remaining petrol from the lawnmower as described on page 15.
2. Turn the machine over and remove the cutting blade.
3. Remove the three screws holding the drive cover, and from above, pinch the retaining clip holding the cover to the machine body. Lift off the cover complete with the blade holder, sliding it off the drive shaft. The drive belt will now come away with the blade holder/driven pulley.

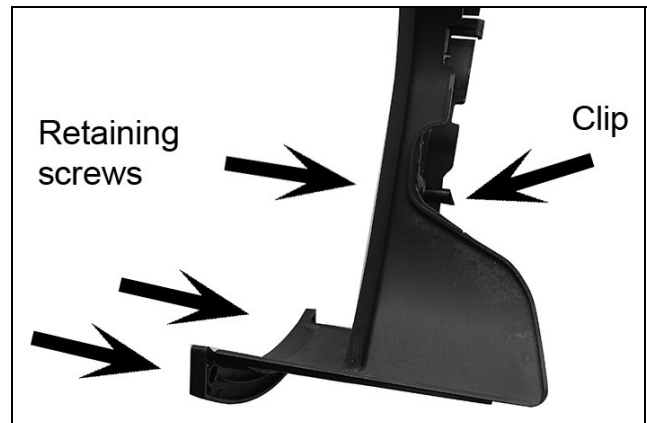

- The illustration shows the belt installed on the pulleys, complete with blade holder. The cover is absent to illustrate this.
4. Replace the defective drive belt and re-fit the blade holder and cover together, noting that a key (spline) engages the blade holder with the drive shaft. Press-fit the cover clip to the machine body and refit the three retaining screws.



GRASS BAG CLEANING AND REPLACEMENT

1. Wash the bag with a garden hose and allow it to dry completely before use; a wet bag will clog quickly.
2. Replace a damaged bag with a genuine bag or its equivalent. Unclip the plastic edges of the bag from the frame. Remove the bag from the frame.
3. Insert the frame into the new bag. Clip the plastic edges to the frame.

ADJUSTMENTS

When the driving lever is released, the engine will stop. The engine will only run with the driving lever held against the main handle. All carburettor adjustments are factory set and will not need adjustment.

STORAGE

If the lawnmower is stored for longer than a month, the fuel tank and carburettor should be drained to avoid the possibility of clogging up from fuel deposits. Ensure the engine is run until it stops for lack of fuel.

FAULT FINDING

ENGINE WILL NOT START

1. Ensure engine speed control is in the start position.
2. Check that there is sufficient fuel in the tank.
3. Check fuel valve is set to ON.
4. Check the condition of the spark plug for cleanliness and correct gap.
5. Excess fuel flooding engine. Dry and reinstall spark plug. Start engine with throttle lever in HIGH position.
6. Petrol may be stale, if so, replace.
7. Fuel filter clogged. Remove and clean filter before re-fitting.
8. Carburettor defect. Take machine to your dealer for repair.

LACK OF ENGINE POWER AND/OR OVERHEATING

1. Check that the throttle lever is in the normal running position.
2. Disconnect the spark plug lead and allow the engine to cool down.
3. Clean grass clippings and debris from around the engine and air inlets and the underside of the machine including the discharge chute.
4. Clean the engine air filter thoroughly as shown on page 17).
5. Petrol may be stale. If so, replace with fresh fuel.

EXCESSIVE VIBRATION

1. Check that the blade is correctly fitted. If the blade is bent or otherwise damaged replace it with a new one.
2. If vibration persists, consult your local Clarke dealer or Clarke Service department.

POOR CUTTING QUALITY

1. Unsuitable height setting. Adjust the cutting height to suit the length of grass especially if grass is too long.
2. Grass box full or clogged. Empty and clean out remaining material.
3. Chassis area clogged with damp grass etc. Shut down machine and clean out clogged material.
4. Blade is blunt or damaged. Sharpen or replace as necessary.

HANDLEBAR COMPONENT PARTS

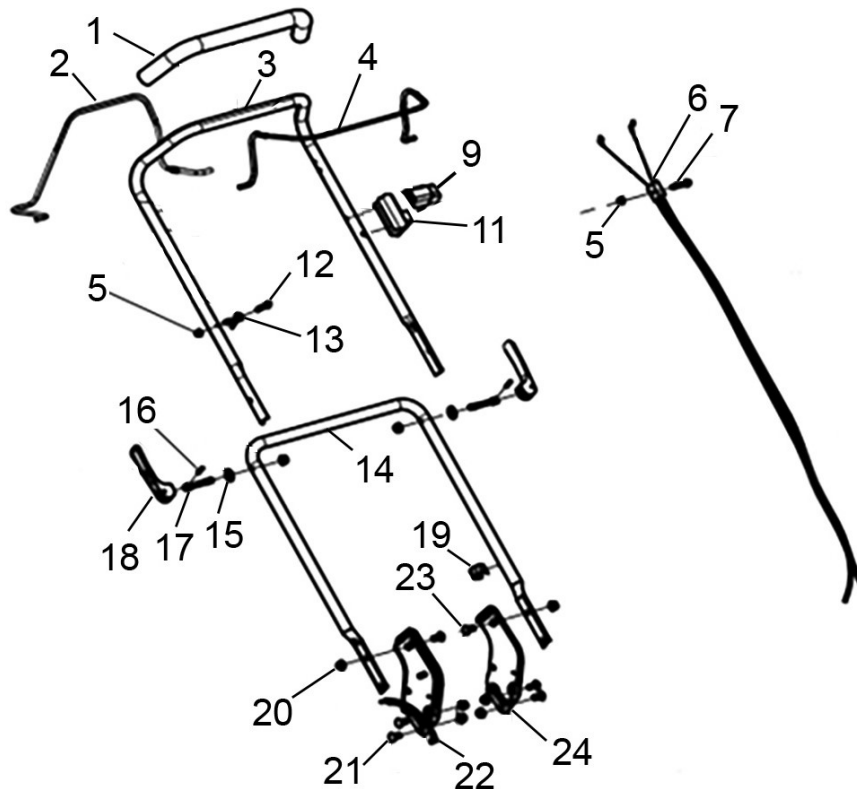

No	Description
1	Sponge Sleeve
2	Driven Lever
3	Handlebar
4	Brake lever
5	Hex nut
6	Cable Assembly
7	Hex flange screw M6 x 35
8	n/a
9	Throttle handle
10	n/a
11	Lever limit block
12	Hex flange screw M6 x 30

No	Description
13	Starting handle loop
14	Lower handlebar
15	Washer
16	Elastic cylinder pin
17	Fast lock screw
18	Fast lock
19	Wire clip
20	Washer
21	Cross head st screw
22	Handlebar fixing seat
23	Carriage bolt
24	Handlebar fixing seat

BODY COMPONENTS

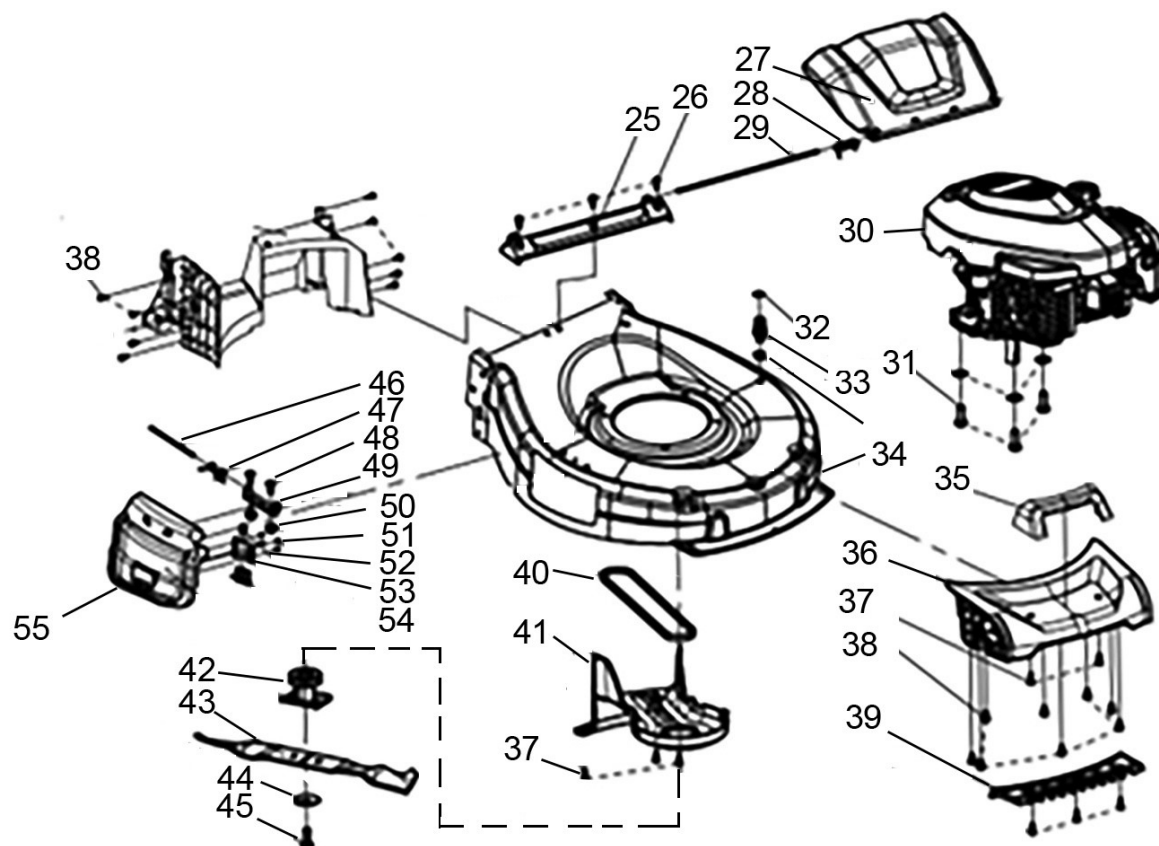

25	Rear cover bottom plate
26	Cross head st screw
27	Rear cover
28	Rear cover spring
29	Rear cover shaft
30	SRV225 vertical shaft engine
31	Hex flange screw M8x25
32	O-ring
33	Washing plug
34	Deck
35	Lifting handle
36	Front decoration panel
37	Cross head st screw
38	Hex head st screw
39	Grass comb
40	Drive belt

41	Belt cover
42	Blade holder
43	Cutting Blade
44	Butterfly washer
45	Hexagon screw
46	Side discharge shaft
47	Side discharge chute spring
48	Square neck screw
49	Side discharge holder
50	Hex flange nut M6
51	Cross head st screw
52	Side discharge chute spring
53	Side discharge chute lock plate
54	Side discharge chute lock
55	Side discharge cover

AXLE COMPONENTS

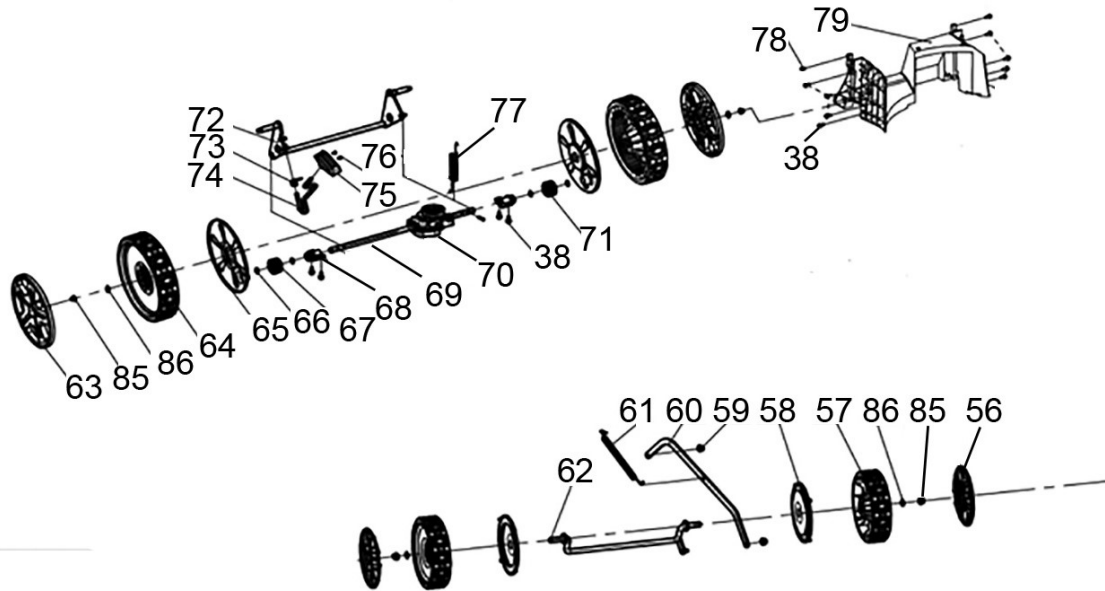

56	8" Wheel cover
57	8" wheel
58	Anti-dust wheel cover
59	Locking nut
60	Connecting lever
61	Connecting lever spring
62	Front axle
63	10" Wheel cover
64	10" Drive wheel
65	Anti-dust wheel cover
66	Shaft retaining ring
67	Driven gear (right)

68	Rear wheel protective sleeve
69	Cylinder pin
70	Gearbox assembly
71	Driven gear (left)
72	Rear axle
73	Height adjustment spring
74	Height adjustment lever
75	Height adjustment handle
76	Cross recessed bolt
77	Gearbox spring
78	Hex flange st screw
79	Rear air duct

COMPONENT SUB ASSEMBLIES

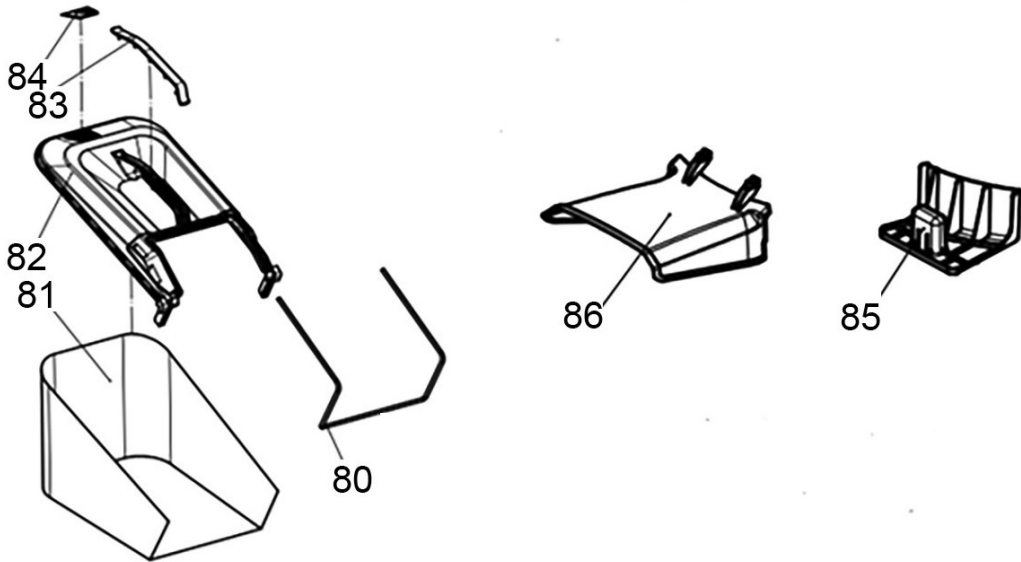

80	Grass catcher frame
81	Grass catcher bag
82	Grass catcher plastic cover
83	Cover handle

84	Catcher Full indicator plate
85	Blanking plate
86	Cover flap

ENGINE COMPONENTS

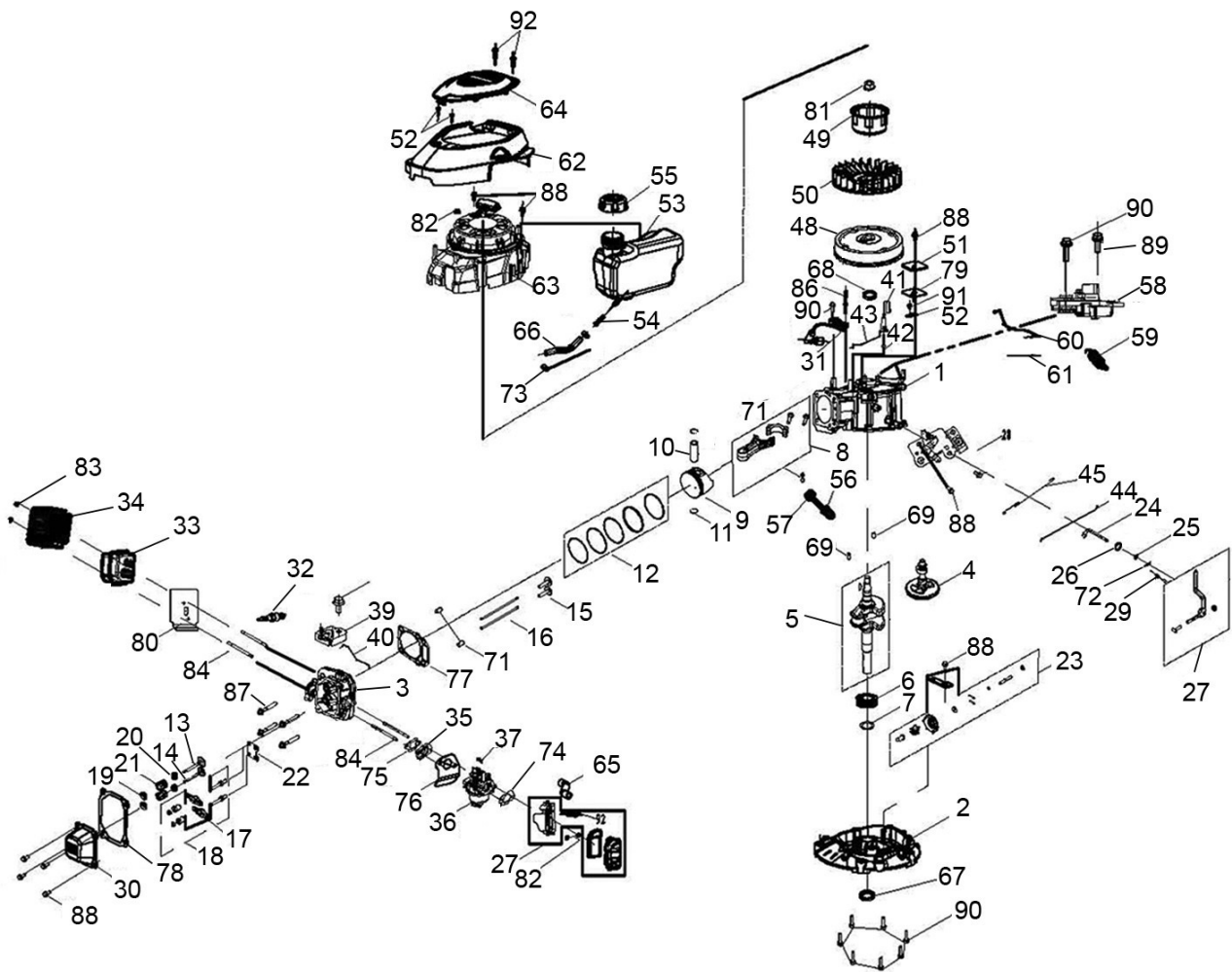

1	Crankcase
2	Crankcase cover
3	Cylinder head
4	Camshaft
5	Crankshaft
6	Crankshaft timing gear
7	Washer
8	Connecting rod assembly
9	Piston
10	Gudgeon Pin
11	Circlip
12	Piston ring set

47	n/a
48	Flywheel
49	Starting cup
50	Impeller
51	Fuel return chamber cover
52	Breathing valve plate
53	Fuel tank
54	Fuel tank filter
55	Fuel filler cap
56	Oil ruler guide pipe
57	Oil ruler
58	Brake assembly

13	Inlet valve
14	Exhaust valve
15	Tappet
16	Pushrod
17	Rocker arm
18	Valve adjustment bolt
19	Inlet spring seat
20	Valve oil seal
21	Valve spring
22	Limit plate
23	Governor gear assembly
24	Governor arm
25	Oil seal
26	Governor arm washer
27	Governor support
28	Throttle assembly
29	Governor spring A
30	Cylinder head cover
31	Ignitor
32	Spark plug
33	Muffler
34	Muffler cover
35	Heat insulation plate
36	Carburetor assembly
37	Lever clip
38	Air cleaner
39	Thermo-switch
40	Temperature control lever
41	Impeller rotator
42	Bolt M6x13
43	Impeller lever
44	Throttle lever
45	Governor spring B
46	n/a

59	Brake spring
60	Shut-down wire
61	Grounding wire
62	Starter cover
63	Recoil starter small cover
64	Cover panel
65	Exhaust pipe
66	Fuel hose
67	Oil seal
68	Oil seal
69	Crankcase location pin 8 x 14
70	Locating pin 8*12
71	Hollow locating pin
72	Cotter pin
73	Spring retaining ring
74	Air cleaner gasket
75	Intake gasket
76	Carburetor gasket
77	Cylinder head gasket
78	Cylinder head cover gasket
79	Fuel return chamber cover
80	Exhaust gasket
81	Nut M14
82	Nut M6
83	Nut
84	Intake stud bolt M6 x 90
85	n/a
86	Stud bolt
87	Bolt M8
88	Hex bolt M6 x 12
89	Hex bolt M6 x 16
90	Hex bolt M6 x 30
91	Pan head screw
92	Pan head screw

DECLARATIONS OF CONFORMITY



DECLARATION OF CONFORMITY

This is an important document and should be retained.

We hereby declare that this product(s) complies with the following legislation: The following standards have been applied to the product(s):

2000/14/EC	Outdoor Noise Directive	EN ISO 5395-1:2013+A1, EN ISO 3744:1995, ISO 11094:1991
2006/42/EC	Machinery Directive	
2016/1628	Particulate Emission and Type-Approval for Non-Road Mobile Machinery	
2011/65/EU	Restriction of Hazardous Substances (RoHS) Directive	

The technical documentation required to demonstrate that the product(s) meet(s) the requirement(s) of the aforementioned legislation has been compiled and is available for inspection by the relevant enforcement authorities.

The UKCA mark was first applied in: 2025

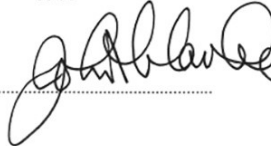
Manufacturer:	Clarke International Ltd, Hemnall Street, Epping, Essex, CM16 4LG, United Kingdom	Notified Body:	TÜV Rheinland LGA Products GmbH (ID: 0197), Tillystraße 2, 90431 Nürnberg, Germany
Product Description:	Lawnmower	Assessment Procedure:	Annex VI of above noise legislation
Model Number(s):	CSP56LM	Measured LWA:	97.26 dB
Serial/Batch Number:	Refer to product/package label	Guaranteed LWA:	98 dB
Document Holder:	Alan Pond	Signed:	 J.A. Clarke Director
Date of Issue:	13/11/2025		

CSP56LM UKCA Clarke DOC 111325

Page 1 of 1



DECLARATION OF CONFORMITY

This is an important document and should be retained.

We hereby declare that this product(s) complies with the following legislation: The following standards have been applied to the product(s):

2000/14/EC	Outdoor Noise Directive	EN ISO 5395-1:2013+A1, EN ISO 3744:1995, ISO 11094:1991
2006/42/EC	Machinery Directive	
2016/1628	Particulate Emission and Type-Approval for Non-Road Mobile Machinery	
2011/65/EU	Restriction of Hazardous Substances (RoHS) Directive	

The technical documentation required to demonstrate that the product(s) meet(s) the requirement(s) of the aforementioned legislation has been compiled and is available for inspection by the relevant enforcement authorities.

The CE mark was first applied in: 2025

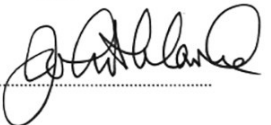
Manufacturer:	Clarke International Ltd, Fitzwilliam Hall, Fitzwilliam Place, Dublin 2, Republic of Ireland	Notified Body:	TÜV Rheinland LGA Products GmbH (ID: 0197), Tillystraße 2, 90431 Nürnberg, Germany
Product Description:	Lawnmower	Assessment Procedure:	Annex VI of above noise legislation
Model Number(s):	CSP56LM	Measured LWA:	97.26 dB
Serial/Batch Number:	Refer to product/package label	Guaranteed LWA:	98 dB
Document Holder:	Alan Pond	Signed:	 J.A. Clarke Director
Date of Issue:	13/11/2025		

CSP56LM CE Clarke DOC 111325

Page 1 of 1

A SELECTION FROM THE VAST RANGE OF

Clarke®

QUALITY PRODUCTS



AIR COMPRESSORS
From DIY to industrial, Plus air tools, spray guns and accessories.

GENERATORS
Prime duty or emergency standby for business, home and leisure.

POWER WASHERS
Hot and cold, electric and engine driven - we have what you need

WELDERS
Mig, Arc, Tig and Spot. From DIY to auto/industrial.

METALWORKING
Drills, grinders and saws for DIY and professional use.

WOODWORKING
Saws, sanders, lathes, mortisers and dust extraction.

HYDRAULICS
Cranes, body repair kits, transmission jacks for all types of workshop use.

WATER PUMPS
Submersible, electric and engine driven for DIY, agriculture and industry.

POWERTOOLS
Angle grinders, cordless drill sets, saws and sanders.

STARTERS/CHARGERS
All sizes for car and commercial use.



PARTS & SERVICE: 0208 988 7400

Parts Enquiries
Parts@clarkeinternational.com

Servicing & Technical Enquiries
Service@clarkeinternational.com

SALES: UK 01992 565333 or Export 00 44 (0)1992 565335

Clarke® INTERNATIONAL Hemnall Street, Epping, Essex CM16 4LG
www.clarkeinternational.com